

## HALL PROBES FOR FH 54 AND FH 55

### ● TRANSVERSE HALL PROBES FOR FH 54, FH 55

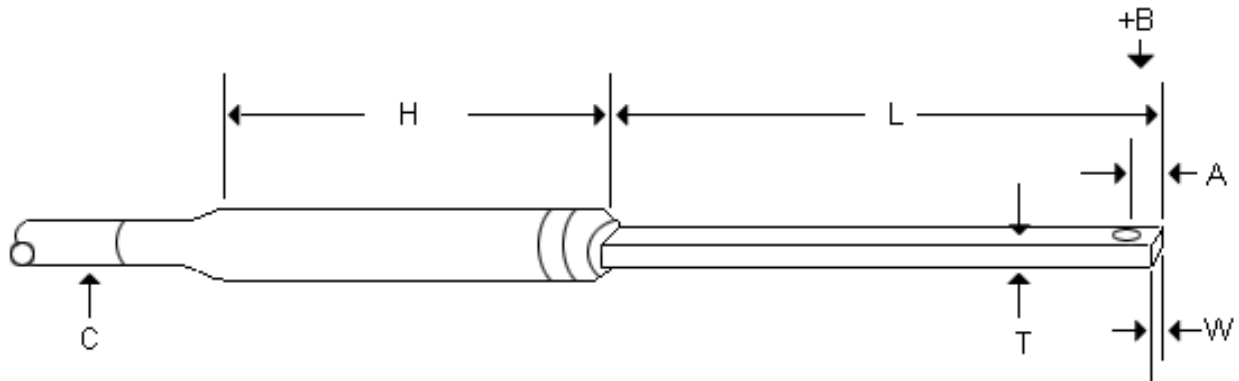

### TRANSVERSE HALL PROBES FOR FH 54, FH 55

Model	HS-TGB5-104005	HS-TGB5-104010	HS-TGB5-104020	HS-TND5-0513026
W	4.0 mm max.	4.0 mm max.	4.0 mm max.	1.3 mm nom.
T (max.)	1.0 mm	1.0 mm	1.0 mm	0.51 mm
L (nom.)	55 mm	100 mm	200 mm	26 mm
A	2 mm ± 0.1 mm	2 mm ± 0.1 mm	2 mm ± 0.1 mm	1 mm ± 0.1 mm
H (nom.)	70 mm	70 mm	70 mm	37 mm
Cable length C	1.5 m	1.5 m	1.5 m	1 m
Stem material	Fibreglas epoxy			Kapton
Active area, nominal diameter	0.4 mm	0.4 mm	0.4 mm	0.64 mm
Ranges, full scale	3 mT to 3 T			
Corrected accuracy [% of Reading, DC]	0.25 % to 3 T	0.25 % to 3 T	0.25 % to 3 T	0.5 % to 1.5 T
Temperature coefficient of sensitivity (maximum) [% / °C]	± 0.02 (T)	± 0.02 (T)	± 0.02 (T)	-0.1

(T): Probe with sensor for temperature correction.  
Operating temperature range 0 °C to 75 °C.

Due to continuous process improvement, specifications are subject to change without notice.

● AXIAL HALL PROBES FOR FH 54, FH 55

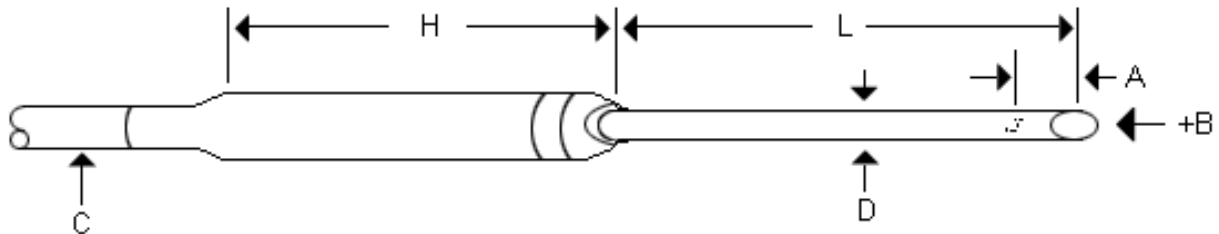

AXIAL HALL PROBES FOR FH 54, FH 55

Model	HS-AGB5-4805	HS-AGB5-4820
D (nom.)	4.8 mm	4.8 mm
L (nom.)	55 mm	200 mm
A (nom.)	0.27 mm	0.27 mm
H (nom.)	70 mm	70 mm
Cable length C	1.5 m	1.5 m
Stem material	Fiberglas epoxy	
Active area, nominal diameter	0.4 mm	0.4 mm
Ranges, full scale	3 mT to 3 T	
Corrected accuracy [% of Reading, DC]	0.25 % to 3 T	0.25 % to 3 T
Temperature coefficient of sensitivity (maximum) [% / °C]	± 0.02 (T)	± 0.02 (T)

(T): Probe with sensor for temperature correction.  
Operating temperature range 0 °C to 75 °C.

Due to continuous process improvement, specifications are subject to change without notice.

**MAGNET-PHYSIK Dr. Steingroever GmbH**

Emil-Hoffmann-Straße 3, D-50996 Köln  
Phone: +49 / (0)2236 / 3919-0 • Fax: +49 / (0)2236 / 3919-19  
e-mail: info@magnet-physik.de  
Website: www.magnet-physik.de

**MAGNET-PHYSICS Inc.**

9001 Technology Drive Suite C-2, Fishers, IN 46038, USA  
Phone: +1 317 577 8700 • Fax: +1 317 578 2510  
e-mail: info@magnet-physics.com  
Website: www.magnet-physics.com