

REMACOMP® C

for computer controlled measurement
of the dynamic characteristics
of soft magnetic materials



• Introduction

The REMACOMP® C family of instruments comprises automatic, computer controlled measuring instruments to determine dynamic (AC) magnetic properties of soft magnetic materials. This information is required in materials research, quality control and system design.

The characteristic quantities are obtained from measurements of the hysteresis loop. The most important properties that can be derived are power losses, remanence, coercivity and permeability.

Many components of the instruments are integrated in the system computer. This minimizes the external cable connections. The output values of the power amplifier can be adapted to specific requirements within a wide range. The instruments cover frequency ranges up to approx. 20 kHz, depending on the selected components.

Typical specimens are ring cores, either solid or tape-wound, stator laminations. They have a closed magnetic path which means that a closure yoke is not necessary. The samples must be equipped with a primary and secondary winding for test.

The magnetic field strength H in the specimen is calculated from the current in the primary winding, which is measured using a precision shunt of negligible inductance. The flux density B is determined by numerical integration of the voltage that is induced in the secondary winding.

The time courses of these voltage signals are simultaneously sampled by two fast analog-to-digital converters. From the data of a period the hysteresis loop and characteristic values like core losses, remanence, coercivity and permeability are calculated.

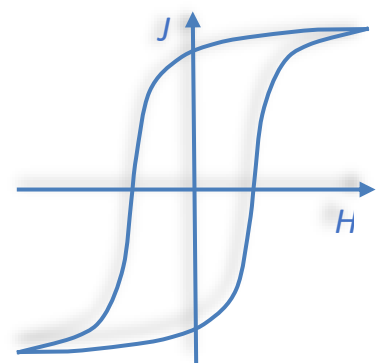



The hysteresis loops appear automatically scaled on the computer monitor. Besides the hysteresis loop, the courses in time of the field strength, the secondary induced voltage and the flux density can be shown. The automatic evaluation of results and the user-configurable graphic display eliminates the need for time-consuming manual evaluation and conversion of data.

The application of digital signal processing techniques throughout the system results in the high degree of accuracy, ease of operation, short measuring time and good documentation. The equipment is therefore suitable for use in the research laboratory or for industrial quality control.

The basic measuring method corresponds to the standard IEC 60404-6 (digital method).

For specimen shapes other than rings, various fixtures are available. Epstein Frames, which are made for the models REMACOMP® C – 1200 and REMACOMP® C - 2200, allows measurements following the standards IEC 60404-2, ASTM A343/A343M and ASTM A889/A889M. With single sheet testers, compliant to IEC 60404-3 and ASTM A804/A804M, or with strip fixtures of different sizes, measurements on sheet and strips in open or closed magnetic circuit are possible.

Multi-turn winding adapters allow e. g. measuring rings and stampings of sheet without applying individual windings.

The REMACOMP® C - 205 can be combined with a REMAGRAPH® C. The REMAGRAPH® C is a hysteresigraph for taking quasi-static (DC) measurements on soft magnetic materials. It meets the requirement of the standards IEC 60404-4 and ASTM A773/A773M.

The main advantage of a true quasi-static measurement is that the hysteresis loop is obtained without the influence of eddy currents. Measurements can be carried out on rings, bars and strips. For details about the capabilities and accessories of the REMAGRAPH® C please consult the data sheet of this instrument.

A REMAGRAPH® - REMACOMP® combination offers both, AC and DC measurements in one instrument. It is more cost-effective compared to two separate instruments as many components

are only required once. But please note that some of these components differ from those used in the separate instruments. So a later extension of a REMAGRAPH® or a REMACOMP® to a combination instrument might require large modifications or may even be impossible.

Only external accessories like measuring fixtures and coils can be added.



REMAGRAPH® - REMACOMP® - Kombination C - 1207

• Measurements

Depending on model and accessories of the REMACOMP® C the following measurements are possible:

- Absolute measurements on specimens with uniform cross-section and a closed magnetic path, like ring or link-type samples. For this type of measurement two windings must be applied to the specimen.
- Relative (comparative) measurements on other specimens that can be equipped with two windings.
- Measurement of strip shaped specimens in an open circuit using an open field coil with measuring coil (surrounding coil).
- Measurements of strips in an Epstein Frame.

• Specimens

The REMACOMP® C allows measuring a variety of materials with different magnetic properties, for example:

- Soft magnetic steel
- Electrical steel
- Ferrous alloys
- Soft magnetic ferrites
- Crystalline Ni-Fe alloys and compounds
- Amorphous magnetic materials
- Nanocrystalline alloys
- Soft magnetic composites (SMC)

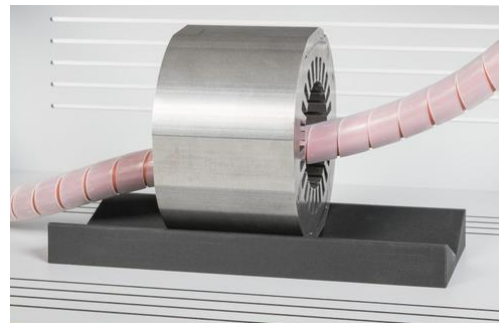

A general specification for an ideal geometric specimen shape cannot be given because the data depend on the specific test and hardware conditions such as frequency, the type of power amplifier, the number of turns of the windings and the magnetic properties of the specimen itself.

Ring specimens can be:

- Solid ring cores
- Sintered cores
- Stator laminations
- Tape-wound cores with round or rectangular (link-type) shape
- Sheet stampings (single samples or stacks)

Typical dimensions of ring specimens are:

- Cross-sectional area 10 mm² to 500 mm²
- Recommended ratio between outer diameter D and inner diameter d : $D/d \leq 1.4$
(ASTM requires $d/D \geq 0.82$ ($D/d \leq 1.22$) for the measurement of material properties)

Test specimens with the following approximate dimensions of outer diameter D , inner diameter d and height h are for example suitable:

$$D = 55 \text{ mm}, \quad d = 45 \text{ mm}, \quad h = 5 \text{ mm}.$$

The maximum field strength H in the specimen depends on the output limits of the power amplifier and the number of turns of the primary winding. For ring shaped samples, the amplitude of the magnetic field strength normally should not exceed 10 kA/m in order to avoid heating of the specimen during the test.

• Product Family

The following REMACOMP® C standard models are available. Main differences are frequency range and output power.

REMACOMP® C - 203

Frequency range : 1 Hz ... 17 kHz in voltage mode
Power amplifier : 50 VA

REMACOMP® C - 205

Frequency range : 1 Hz ... 19 kHz in voltage mode
Power amplifier : 200 VA

REMACOMP® C - 1200

Frequency range : 1 Hz ... 20 kHz
Power amplifier : 1100 VA

REMACOMP® C - 2200

Frequency range : 1 Hz ... 20 kHz
Power amplifier : 2 × 1100 VA



Cabinet of REMACOMP® C - 1200, housing one power amplifier

The low output power REMACOMP® C - 203 is mainly designed for measuring ring specimens of Fe-Ni or other magnetically very soft alloys.

The REMACOMP® C - 205 is mainly intended for measurements on ring specimens. It can optionally be equipped with an Epstein frame (with limited capabilities) or with a single strip fixture.

The REMACOMP® C – 1200, or in a version with higher power rating as REMACOMP® C – 2200, are especially suitable for use with an Epstein frame or a single sheet tester (SST) for electrical steel testing. Available are 25 cm Epstein frames that are optimized for measurements at power line frequencies (50 Hz / 60 Hz) but can be used from 1 Hz to approx. 400 Hz. An Epstein frame for high frequencies (up to 10 kHz) is optionally available.

Shielded connection boxes for ring specimens are included with the REMACOMP® C - 1200 and C - 2200 models. With the REMACOMP® C - 203 and C - 205, the specimens are connected directly to the front panel of the cabinet.



The REMACOMP® C - 2200 is predestined for measurements on larger ring cores and stators.

The models REMACOMP® C - 203, C - 205, C - 1200 and C - 2200 feature a digital waveform control, to maintain a sinusoidal secondary induced voltage U_2 or flux density B , even at relatively high excitation.

Various power amplifiers with different output power, voltages and currents are optionally available. The optimum choice depends on the specimens to be measured (material, dimensions, application frequency). If you supply information about your application we can assist you by configuring an optimally customized system.

It is generally advisable not to choose more amplifier power than needed to have a good resolution and a low noise performance.

REMAGRAPH® - REMACOMP® combinations allow measuring quasi-static (DC) as well as dynamic (AC) hysteresis loops with one instrument. The low power REMAGRAPH® - REMACOMP® Combination C - 803 is especially suitable for measuring ring specimens of Fe-Ni or other magnetically very soft alloys.

The more powerful combination C – 805 allows the comfortable measurement of materials with higher coercive field strengths than Fe-Ni.

The combination C – 810 combines a REMAGRAPH® C - 600 with a permeameter according to IEC 60404-4 for DC measurement of rod and strip samples with a REMACOMP® C - 205 for AC measurement of ring samples.

The combination models C - 1207 and C - 2207 are very powerful and are optimized for AC and DC measurements of standard electrical sheet samples as well as components such as stators. They can be operated with an Epstein frame, single sheet tester, or stator tester.



REMAGRAPH® - REMACOMP® -
Kombination C - 805

REMAGRAPH® - REMACOMP® Combination C - 803

For measurements on ring specimens, including one Electronic Fluxmeter EF 7
 Frequency range : DC, 1 Hz ... 17 kHz in voltage mode
 Power amplifier : ± 20 V, ± 5 A

REMAGRAPH® - REMACOMP® Combination C - 805

Combination of REMAGRAPH® C - 630 and REMACOMP® C - 205, for measurements on ring specimens, including one Electronic Fluxmeter EF 7
 Frequency range : DC, 1 Hz ... 19 kHz in voltage mode
 Power amplifier : ± 36 V, ± 12 A

REMAGRAPH® - REMACOMP® Combination C - 810

Combination of REMAGRAPH® C - 600 and REMACOMP® C - 205, including two channel Electronic Fluxmeter EF 7, MJR 5 measuring yoke and JRR, JRF, PS-R 40/58 measuring coils (for details please consult the REMAGRAPH® C data sheet).
 Frequency range : DC, 1 Hz ... 19 kHz in voltage mode
 Power amplifier : ± 36 V, ± 12 A

REMAGRAPH® - REMACOMP® Combination C – 1207

Like a REMACOMP® C - 1200, with one additional Electronic Fluxmeter EF 7
 Frequency range : DC, 1 Hz ... 20 kHz
 Power amplifier : approx. ± 150 V, ± 30 A (load dependent)

REMAGRAPH® - REMACOMP® Combination C – 2207

Like a REMACOMP® C - 2200, with one additional Electronic Fluxmeter EF 7
 Frequency range : DC, 1 Hz ... 20 kHz
 Power amplifier : approx. ± 150 V, ± 60 A (load dependent)

• Operating Principle

The block diagram shows the main components of the REMACOMP® C with a ring shaped test specimen (3) that is equipped with a primary and a secondary winding.

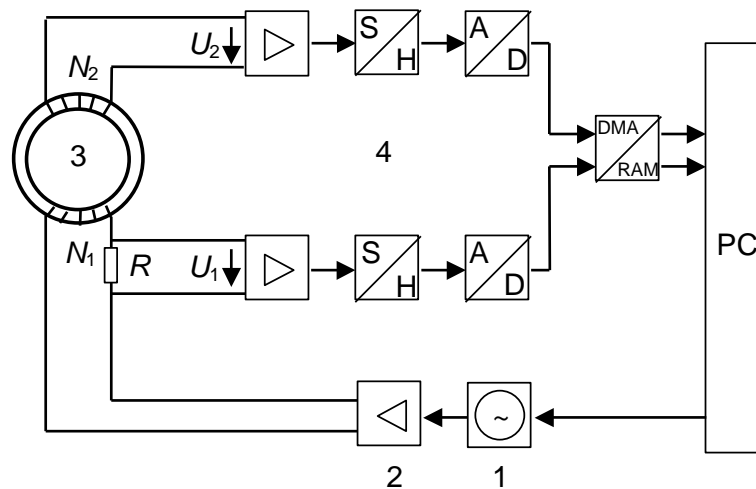

Measuring principle of REMACOMP® C: 1 signal generator, 2 power amplifier, 3 specimen, 4 data acquisition system

Frequency, amplitude and waveform are programmed to the signal generator (1). Its output signal drives the power amplifier (2). The primary winding with N_1 turns is connected to the output of the power amplifier, in series with the low inductance precision shunt R . The voltage drop $U_1 = R \cdot I$ across the shunt is proportional to the magnetic field strength H in the specimen.

The voltage U_2 that is induced in the secondary winding is proportional to the flux variation $d\Phi / dt$. The flux density B is obtained from U_2 by numerical integration. Both voltages U_1 and U_2 are synchronously sampled by two fast analog-to-digital converters (4). The resulting data are stored in the PC for further processing. The hysteresis loop is displayed.

In addition, the measurement data stored in the computer can also be used for other purposes, e.g. statistical analysis or quality documentation of incoming or outgoing products.

The REMACOMP® is easy to use, with a menu-based, user-friendly graphical interface. Once the required parameters have been set, the push of a button is all that is needed to start the fully automatic measurement process.

The use of an external power amplifier offers the possibility to adapt the system easily to different measurement purposes.

Among others, the following quantities are automatically calculated from the measured data:

- Core loss,
- Specific loss
- Remanence
- Coercivity
- Permeability
- Form factors of H , U_2 and B resp. J
- Maximum field strength
- Maximum flux density

• Epstein Frame and Single Sheet Tester for REMACOMP® C - 1200 / C – 2200

Mostly at power line frequencies (50 Hz or 60 Hz), less frequently also at lower frequencies or up to 10 kHz, measurements on electrical sheet and strip (Silicon-Iron) are carried out using an Epstein frame. Normally measurements are performed in an excitation range of the flux density B for grain oriented material from 1.0 T to 1.8 T and for non-oriented material from 0.8 T to 1.5 T. The following properties are measured:

- Specific losses
- Specific apparent power
- Peak value of magnetic polarization
- Peak value of magnetic field strength
- Hysteresis loop

The measuring setup requires a low impedance voltage source that is very stable in voltage and frequency. The curve shape of the secondary induced voltage (or the flux density) must be kept as sinusoidal as possible to obtain comparable results. Therefore, the REMACOMP® C – 1200 / C - 2200 uses digital waveform control.

The Epstein frame has an average width of 250 mm. It consists of four identical coil systems that are arranged in a square. Each of them contains a primary and a secondary winding, which are 190 mm long.



Epstein Frame

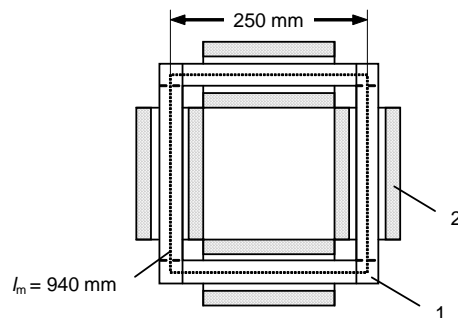

1: Sample, 2: Turns

The secondary winding (flux measuring winding) is first wound on the coil former, so that it captures as little air flux as possible. The primary winding (field generating winding) is arranged on top of the secondary. The four coils of the primary winding are wired in series, as are those of the secondary winding.

The number of turns must be chosen with respect to the desired operating frequency range and the sensitivity of the data acquisition system. The Epstein frame included in the REMACOMP® C – 1200 / C - 2200 standard package is optimized for 50 Hz to 60 Hz operation.

The frame is filled with the specimen to be measured, so that the corners of the strips are overlapping alternately.

The single strips are between 280 mm and 320 mm long and 30.0 mm ± 0.2 mm wide. Their number must be a multiple of 4. The mass of the specimen should generally be at least approximately 300 g if the strips are 280 mm long. But, due its high sensitivity, the REMACOMP® C - 1200 / C - 2200 can often measure on specimens with an even lower mass.

For non-oriented material, half of the strips are cut in the rolling direction and the other half perpendicular to it. The strips cut perpendicular to the rolling direction must be placed at opposite sides.

Due to the overlapping corners, the magnetic path length l_m , which is required to calculate the field strength in the specimen, cannot be determined exactly. It is therefore defined to be 0.94 m per the applicable standards.

The measuring coils of an Epstein Frame are wound onto coil formers and not directly onto the specimen. Usually the coil formers are not completely filled by the specimen. Therefore, in addition to the flux in the specimen, the coils also capture a considerable amount of air flux. This air flux must be compensated. After compensation the polarization J in the specimen can be derived directly.

The traditional way of air flux compensation is to apply a mutual inductance. It is adjusted so that the output of the measuring winding is zero if no specimen is inserted in the frame.

Although the applicable standard IEC 60404-2 covers the use of digital methods, it states normatively that an analog mutual inductance must be used. Therefore, the standard Epstein frame of the REMACOMP® C - 1200 / C - 2200 incorporates a mutual inductance.



10 kHz Epstein Frame

An Epstein frame for higher frequencies is optionally available for the REMACOMP® C - 1200 / C - 2200. It has two primary windings with different numbers of turns that can alternately be used. In this way the frame can be used in a frequency range up to 10 kHz.

At high frequencies a mutual inductance would induce additional errors due to its inter-winding capacitance. Therefore a high frequency Epstein frame does not use a mutual inductance but numerical air flux compensation. Therefore an empty reference measurement (without specimen) is first carried out to determine the area turns necessary for compensation. By applying this compensation factor, a numerical compensation is carried out later for each measurement on specimens. This is in accordance with the standards IEC 60404-10, EN 10252 and ASTM A348/A348M.

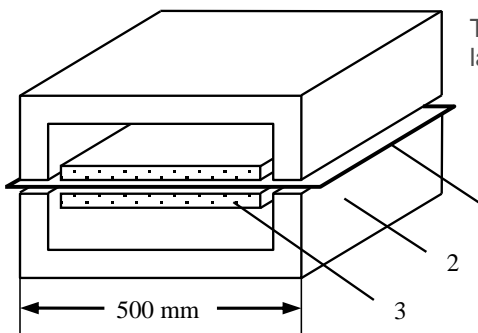

Single Sheet Tester MJC 500
1: Sample, 2: Yoke, 3: Windings

The Single Sheet Tester according to IEC 60404-3 consists of two identical lamellate yoke halves that close the magnetic circuit above and below the sheet specimen to be measured. The cross-section of the sheet packets from which the yokes are made must be large compared to the cross-section of the specimen. Between the yoke halves, there are primary and secondary turns. The sheet specimen is inserted into these. As with the Epstein frame the secondary winding is located inside on the coil former and the primary winding is located outside.

The yoke consists of a stack of isolated sheets. This is necessary to minimize eddy currents. Single sheet testers from MAGNET-PHYSIK are made of bent cores. Opening and closing of the yokes of the type MJC 500 single sheet tester is made by an electric drive. Precision mechanics ensures parallelism of the yoke halves. Both halves are moved away from the specimen to avoid wear of the pole faces.

The specimen for the single Sheet Tester MJC 500 should have a minimum width of 500 mm and should fill 60 % of the yoke depth at minimum. For grain-oriented material it is advantageous to use square specimens. This allows measurements to be carried out in rolling direction and perpendicular on the same specimen. Test from DC to 100Hz are possible.

The main advantage of the single sheet tester is the easier specimen preparation, compared to the Epstein frame. On the other hand the yoke construction is much more demanding.



Single Sheet Tester MJC 500

We offer next to the single sheet tester MJC 500 as well smaller single sheet testers, mainly for laboratory use.

The following picture shows the single sheet tester MJC 210 which is suitable for sheets with a minimum length of 210 mm and a maximum width of 210 mm. In contrast to the single sheet tester MJC 500, the yoke of this device is opened and closed manually. The MJC 210 is designed as a compact cost-efficient yoke. Conformity with IEC 60404-3 is established via comparison measurements with the MJC 500. The compact design allows measurements from DC to 1kHz (depending on the amplitude and sample).



Single Sheet Tester MJC 210

• Measurement of tensile and compressive stress on single sheet samples

The magnetic properties of depend heavily on stresses in the material. These can arise during various machining processes or, for example, through winding or pressing stators into housings. The open design of the MJC 210 sheet measuring device allows tensile stress to be applied to the sheet. A tension unit is not part of the MJC 210.

The application of compressive stresses is technically more complex and places special demands on the measuring yoke, as the sheets bulge and buckle under pressure if this is not ensured by close guidance through a stable special yoke. The MJC 210 tension-compression is specially designed for measuring sheet samples under compressive stresses, a segmented, extremely stiffened coil system provides the necessary stability. The upper half of the yoke can be locked in place and the entire MJC 210 Tension-Compression can be integrated into a mechanical set-up using fixing points. An outstanding feature is that tests can be carried out on relatively large sheet samples with a width of 210 mm and not just strip samples, meaning that cutting edge effects are negligible. A mechanical printing device is not part of the yoke. The yoke is specified up to an application of 7 kN. The resulting compressive stress depends on the cross-sectional area of the sample; approx. 20 MPa is typical for electrical steel samples. Tensile stresses are not limited by the yoke and can be applied up to the tensile yield strength.



The Single Sheet Tester MJC 210 Tensile and Compressive Pressure

• Single Strip Tester

Unlike in strip production, only small sample quantities and dimensions are available, especially in material development. This makes measurement using standard-compliant yokes (500mm x 500mm) and Epstein frames impossible and makes it necessary to switch to small measuring yokes. These enable comparative, non-absolute measurement on small sample strips.



MJC 104586

The MJC 104586 is a coil system with yoke for measuring the magnetic properties of soft magnetic strips with the REMACOMP, available with connectors suitable for all REMACOMP models. The tester is optimized for comparative measurements for low frequencies around 50Hz.

Maximum sample thickness: 1 mm
Maximum sample width: 45 mm
Minimum sample length: 86 mm
Maximum frequency: approx. 1 kHz

As with all yokes, the losses of the yoke limit the applicability at high frequencies. In order to meet our customer requirements for strip samples at high frequencies, we also offer high-frequency strip testers as accessories as follows.

• High Frequency Single Strip Tester

The high-frequency strip tester uses a high-quality symmetrical yoke, which itself has the lowest possible losses. The number of turns of the yoke is optimized for high frequencies.



MJC 1030110

The MJC 1030110 is directly compatible with the models REMACOMP C - 203, 205 and combinations C-703, 705, 803, 805. These less powerful models are ideal for low-noise measurements. The MJC 1030110-1200 variant is intended for connection to the more powerful REMACOMP models C-1200 and C-1207.

Maximum sample thickness: 1 mm
Maximum sample width: 30 mm
Minimum sample length: 110 mm
Maximum frequency: approx. 20 kHz

The design of the yoke is optimized for high frequencies. For example, the following field strengths H can be achieved on a strip sample made of M111-35 A:

$H_{\max} = 1300 \text{ A/m}$ at 50Hz to 20.000Hz
 $H_{\max} = 5000 \text{ A/m}$ at 50Hz to 20.000Hz

MJC 1030110
MJC 1030110-1200

at C - 205 / C - 805
at C - 1200 / C - 1207

• Component Testing



The CB-L and CB-S winding adapters, also known as stator testers, allow stator laminations and large ring samples to be connected quickly. The measuring principle is similar to the measurement of toroidal cores in accordance with IEC 60404-6.

To record the magnetic hysteresis curve (BH curve), a magnetic field H is applied to the sample and the induced flux density B in the sample is measured. This is done with a tester cable consisting of a primary winding $N1$ (to generate H) and a secondary winding $N2$ to pick up B . The

air flow between $N1$ and $N2$ can be compensated by the Remacomp's Comp software. The tester cable is fed through the inner passage of the sample.

The stator tester works with very high current densities during the fast measurement. To protect against these high current densities, the stator tester is equipped with a temperature-resistant cable that is temperature-monitored twice and protected with safety circuits. A cover protects the tester cable from damage caused by sharp metal edges.

The tester is operated together with the powerful Remacomp Model C - 2200, which takes over the complete device safety and allows the current to flow in parallel with two amplifiers. The Remacomp C - 2200 also supports the device functions "overheating alarm" and "cooling fan".

• Statortester CB-S (for REMACOMP® C - 2200)

This tester was specially developed for stators. It enables the quick connection of stators and large toroidal specimens. The measuring principle is based on the measurement of a toroidal core in accordance with IEC 60404-6. To test the magnetic hysteresis curve (BH loop), a magnetic field strength H must be applied to the sample and the induced flux density B in the sample must be measured. This is done with a test cable that contains the primary windings $N1$ (to generate H) and the secondary windings $N2$ to pick up B . The air flow between $N1$ and $N2$ can be compensated in the Comp software of the Remacomp system. It uses a plug-in connection with 18 contacts to close a prefabricated winding through a ring-shaped sample (stator). The resulting winding has 16 primary turns and 2 secondary turns. The smallest inner sample diameter is 35.5 mm. The maximum outer diameter of the stators is 200 mm. The maximum length of the stators is 250 mm. The mass of the stators should not exceed 20 kg. The CB-S has three separate safety circuits to ensure safe operation.



- **Statortester CB-L** (for REMACOMP® C – 2200)

Like the smaller CB-S, this tester was developed for measuring stators and follows the same principle. It uses a plug-in connection with 18 contacts to connect a prefabricated winding through a ring-shaped sample (stator). The resulting winding has 16 primary turns and 2 secondary turns. The smallest inner sample diameter is 35.5 mm. The maximum outer diameter of the stators is 400 mm. The maximum length of the stators is 400 mm. The mass of the stators should not exceed 100 kg. To ensure safe operation, the CB-L has three separate safety circuits, a stable measuring cabinet with two wide-opening front doors. The lid, which is also designed as an opening, allows heavy stators to be loaded with samples by crane. The CB-L is designed for the safe feeding and positioning of large samples.



- **Features of COMP – Software for REMACOMP®**

The magnetic field strength H for the excitation of the specimen is controlled from the PC via a programmable signal generator. The input signals required for the calculation of the field strength H and flux density B are synchronously sampled by two fast analog-to-digital converters. Range settings are automatically controlled by software. When the desired excitation level is reached, the hysteresis loop is displayed on the computer screen.

A time- and work-saving feature is the possibility to store preset specimen and measuring parameters. Thus, in the case of new measurements, only a few new inputs must be made. This is especially useful for measurement sequences on similar specimens. For successive measurements, the final settings of the last measurement are available as new start settings.

The measured results and curves can be output on the monitor, printer or in result files, which can then be further processed by programs such as Excel® etc. This allows statistical treatments of a series of measurements to be carried out.

- **General Features**

- Flexible, user friendly operation using menus, function keys and shortcut keys or icons
- Extensive help file, context-sensitive help
- Convenient input of measuring parameters
- Saving and opening of parameters and measuring data
- Multiple measurements can be simultaneously opened for easy comparison
- Existing measurements can serve as templates for new measurements
- Automatic calculation of measured results
- Automatic saving of measured data, parameters and results (e. g. under a test name or number)
- Saving of a group of associated measurements into a single file
- Export of measured data, parameters and results to text files or to Microsoft Excel® files
- Export of parameters and results to text databases or SQL databases, database viewer in the software
- Print preview for measurement diagrams with curves, parameters and results
- Output of measurement diagrams to a printer or pdf writer (printer and pdf writer not included)
- Copying of measurement diagrams and result lists via the Windows® clipboard
- Saving measurement diagrams as pictures (bmp, gif, jpeg, png) for easy distribution
- Various possibilities for customer specific output design like selection of curves, calculated results, units, measuring parameters, user-definable information texts, company logo, etc.
- User-definable limit classifiers for all results (out of range results are shown in red or boldface)

- Display of multiple curves in one diagram including results
- Optional display of averaged results of multiple measurements in the diagram
- Different output diagram layouts can be saved for easy switching between different outputs
- Selectable units for magnetic quantities, temperatures, specimen dimensions and other parameters
- Full support of SI and CGS units in software and output, changing units is possible at any time
- Simultaneous display of results in mixed SI and CGS units can be configured by the user
- The number of significant digits to be displayed for results can be selected by the user
- Creating of result lists for multiple measurements incl. possibility of saving, copying and printing
- Program menu access can be restricted for selected users (password protection)
- Language separately selectable for program menus and output (English, German, French, Spanish, Polish, Czech, Slovak, Russian, Chinese (simplified))
- Microsoft Windows® 7 / 8 / 10 / 11 compatible

• Parameters

- Default parameters minimize the number of necessary inputs
- Calculation of the cross-sectional area of rings and rectangular cores (e. g. split-tape cores)
- Calculation of the magnetic path length of rings and rectangular cores
- User-extensible database for data of standard cores, e. g. C-cores
- Automatic use of the standard density of the respective grade for measurements on electrical steel
- Input or selection of fixture data for Epstein frames or single strip fixtures
- Input of room and specimen temperatures in °C, °F or K
- Possibility for numerical air flux compensation if the secondary winding is not directly wound onto the specimen (core box)
- Possibility of considering the influence of an air gap (sheared hysteresis loop)
- Extensive parameters verification to avoid illegal or inconsistent settings

• Measurements

- Complete hysteresis loop with setting of the desired excitation level for the field strength H or flux density B resp. polarization J
- Normal magnetization curve (commutation curve) with automatic or manual setting of the desired excitation levels for the field strength H or flux density B resp. polarization J
- Loss measurement $P(H)$, $P(B)$ or $P(f)$ with automatic or user definable excitations of H , B or f
- Standard waveforms and user definable waveforms, waveform designer software included
- Waveform control towards sinusoidal or other predefined waveforms of U_2 or B
- Option for smoothing by averaging measurements over multiple periods
- Series measurement feature: allows automatically running a sequence of different measurements on the same specimen, e. g. different excitations or different measuring types
- Automatic room temperature recording with optional room temperature sensor
- Automatic specimen temperature recording with optional non-magnetic (type-T) thermocouple and optional thermocouple interface

• Evaluation

Hysteresis Measurements

- Hysteresis loop
- Total loss density P , specific total loss P_s or total power loss (core loss) P_c in the corresponding units W/m^3 , W/kg , W
- Apparent power density S , specific apparent power S_s or apparent power S_c in the corresponding units VA/m^3 , VA/kg , VA
- Remanence B_r
- Coercivity H_c
- Maximum field strength H , polarization J and flux density B
- Amplitude permeability, either as relative permeability or inductance factor (A_L value)
- Form factors of field strength H , secondary induced voltage U_2 and flux density B
- Root mean square values of H , J and B
- Tables of $J(H)$ or $B(H)$, where H are user defined field strengths. The values of H can be stored.
- Tables of $H(J)$, $H(B)$, where J or B are user defined values. The values of J or B can be stored.
- Temperature correction: Possibility of considering temperature coefficients of B_r or H_c

Commutation Curve and Permeability Measurements

- Commutation curve $J(H)$ and $B(H)$



- Amplitude permeability: $\mu(H)$ and $\mu(B)$ curves
- Maximum amplitude permeability μ_{\max} and corresponding field strength $H(\mu_{\max})$
- Curve fit for extrapolation of initial permeability μ_i
- Tables of $J(H)$, $B(H)$, $\mu(H)$, where H are user defined field strengths. Very useful for material definitions in FEM programs. The values of H can be stored.
- Tables of $H(J)$, $H(B)$, where J or B are user defined values. The values of J or B can be stored.

Loss Measurements

- Power loss: Total loss density P , specific total loss P_s or total loss (core loss) P_c in the corresponding units W/m^3 , W/kg , W
- Energy loss or loss per cycle: Total loss density W , specific total loss W_s or total loss (core loss) W_c in the corresponding units J/m^3 , J/kg , J
- Curves $P(H)$, $P_s(H)$, $P_c(H)$ or $P(B)$, $P_s(B)$, $P_c(B)$ or $P(f)$, $P_s(f)$, $P_c(f)$, $W_s(f)$
- Tables of $P(H)$, $P_s(H)$, $P_c(H)$ where H are user defined field strengths. The values of H can be stored.
- Tables of $P(B)$, $P_s(B)$, $P_c(B)$ where B are user defined flux densities. The values of B can be stored.
- Tables of $P(f)$, $P_s(f)$, $P_c(f)$ where f are user defined frequencies. The values of f can be stored.
- Loss separation: hysteresis loss, eddy current loss and residual loss (anomalous excess loss)

General

- User values for result tables can be predefined and stored. The corresponding functional values are automatically interpolated.
- Output of specimen and measurement parameters, data points and calculated results to ASCII text files, Microsoft Excel® worksheets (xlsx) or Microsoft Excel® xml spreadsheets
- Output of sample and measurement parameters and calculated results to databases

Microsoft Excel® and a SQL server are not included. Windows 10 normally includes "Microsoft Print to PDF", which allows an automatic creation of PDFs of the measurement diagrams by *COMP*, without further user interaction.

• Control

Operation of the Remacomp® C requires a personal computer to control the measurement course. The computer that is included in the standard packages has the following minimum configuration:

- LCD display
- Keyboard, mouse
- Hard disk drive
- Network interface
- Interfaces (COM, USB as required)
- Microsoft Windows® operating system (Windows 10)

The computer must be configured by MAGNET-PHYSIK. We can only guarantee faultless operation if, apart from the programs installed by us or standard office programs, no further software is installed.

• Screenshots

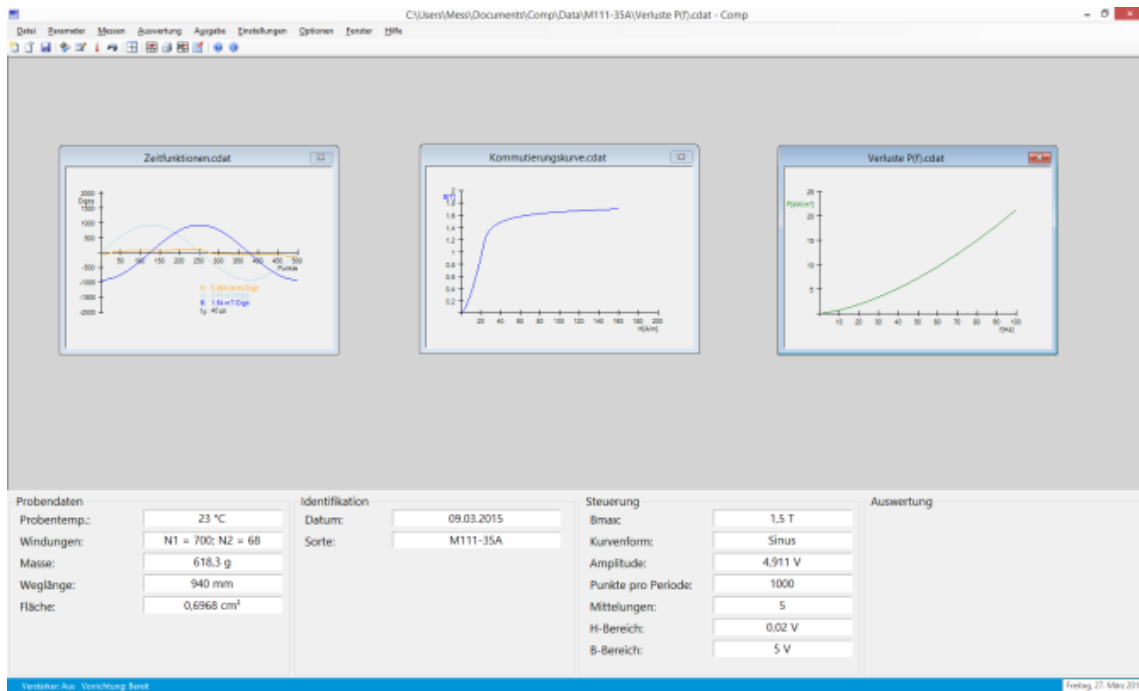

Main window with various measurements

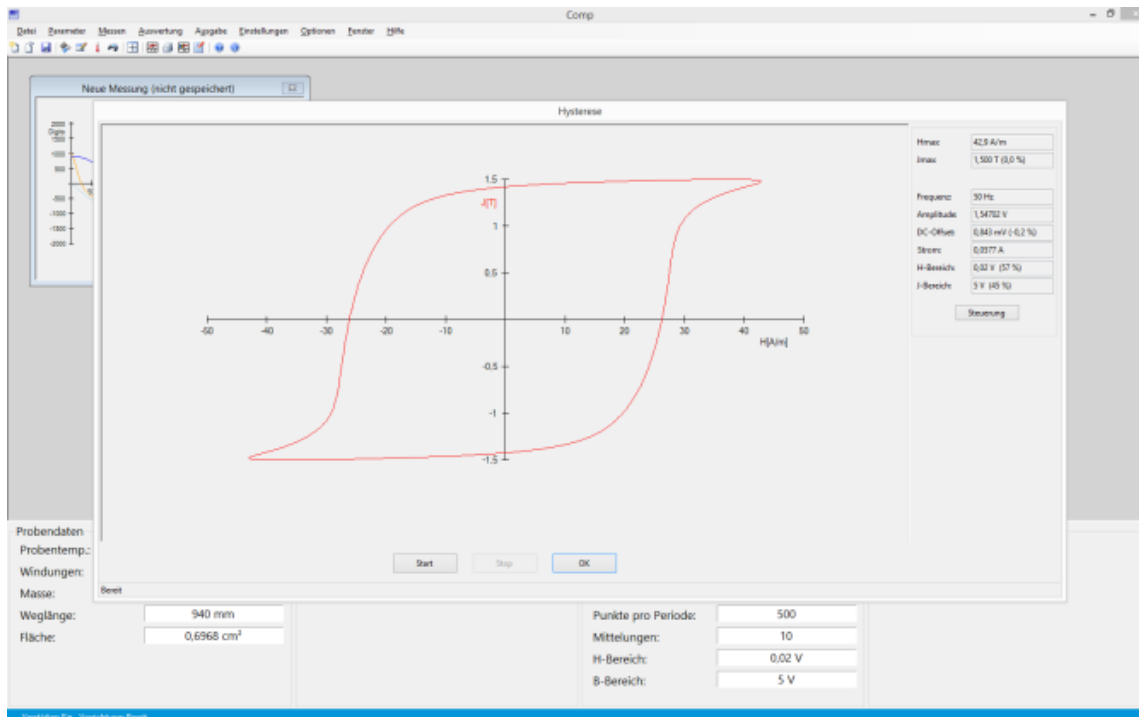

Hysteresis measurement

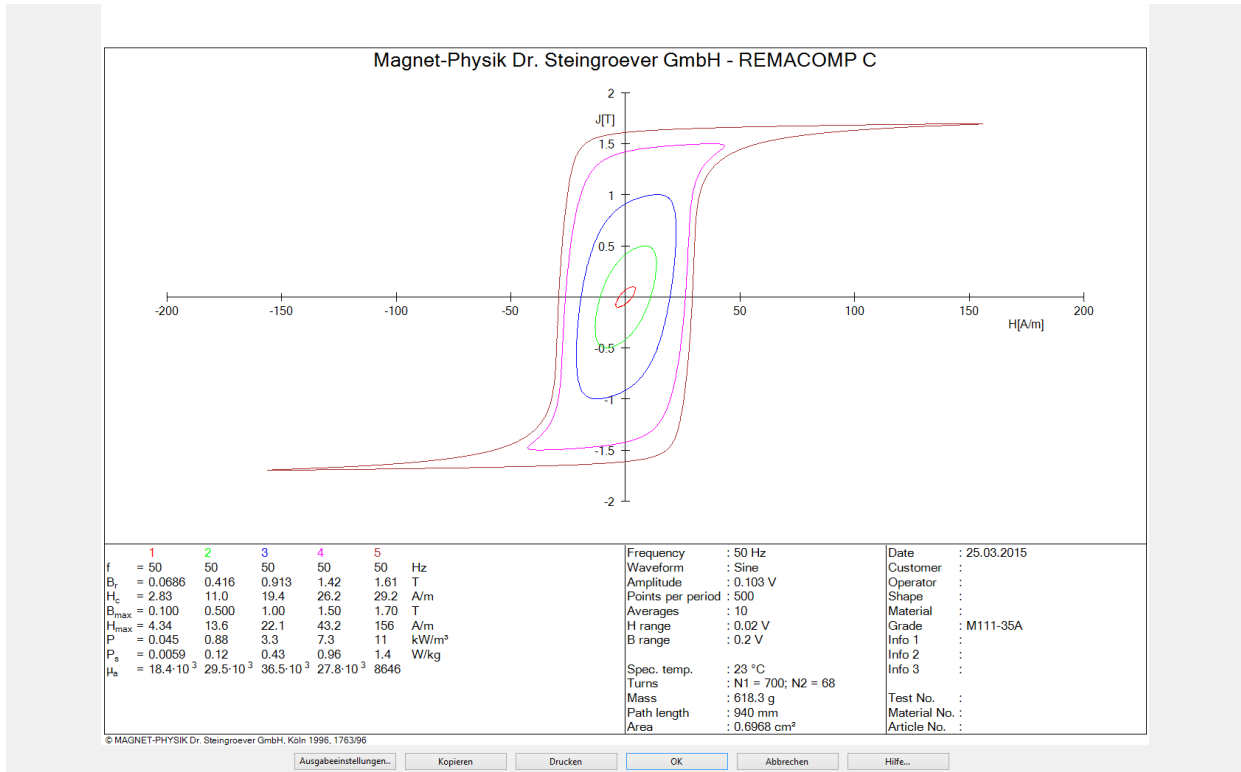

Result output of several hysteresis curves

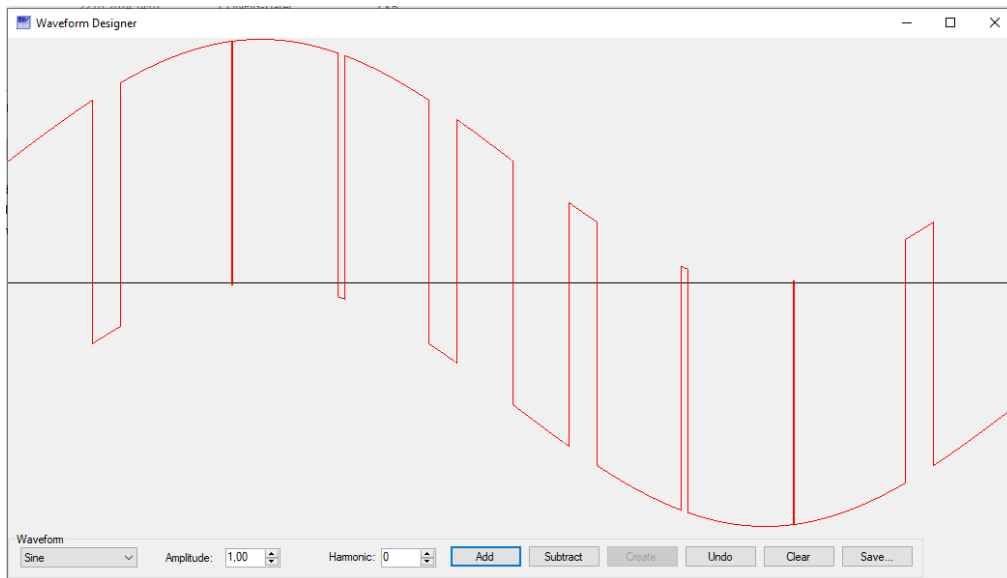

Waveform Designer for creating any waveform with a click

• Example Diagrams

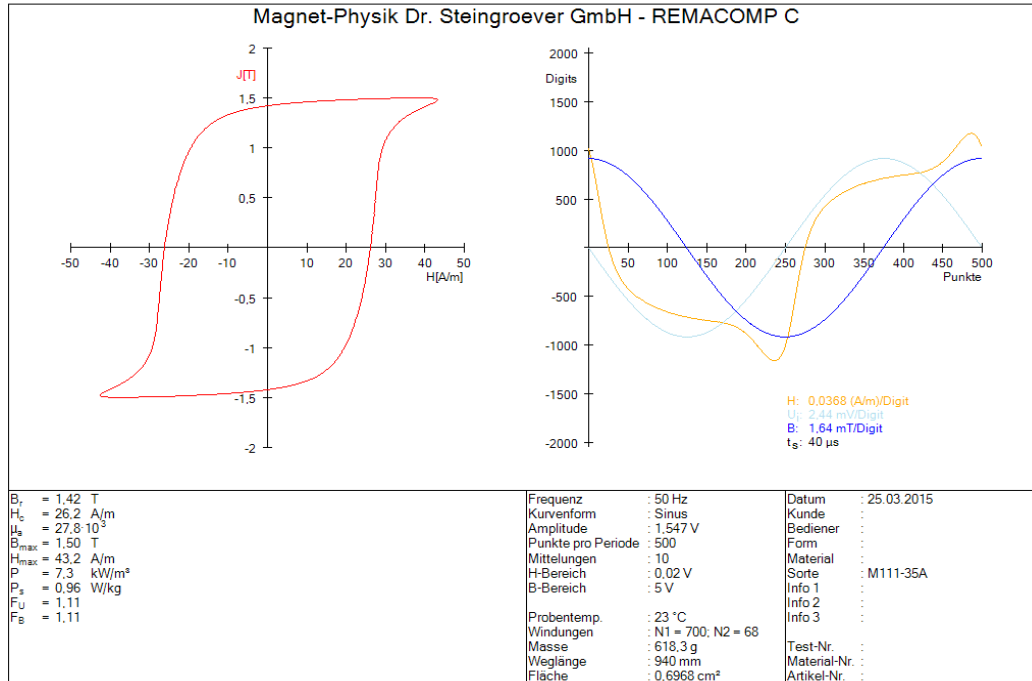

Hysteresis loop and time functions of the field strength, the secondary voltage and flux density

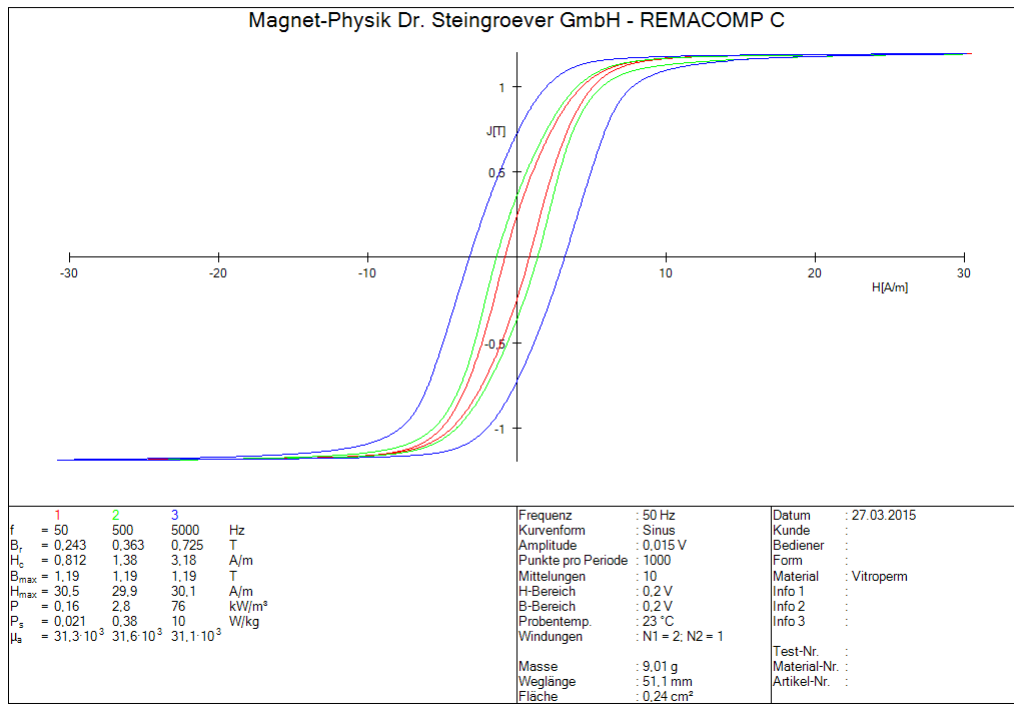

Hysteresis loops at different frequencies

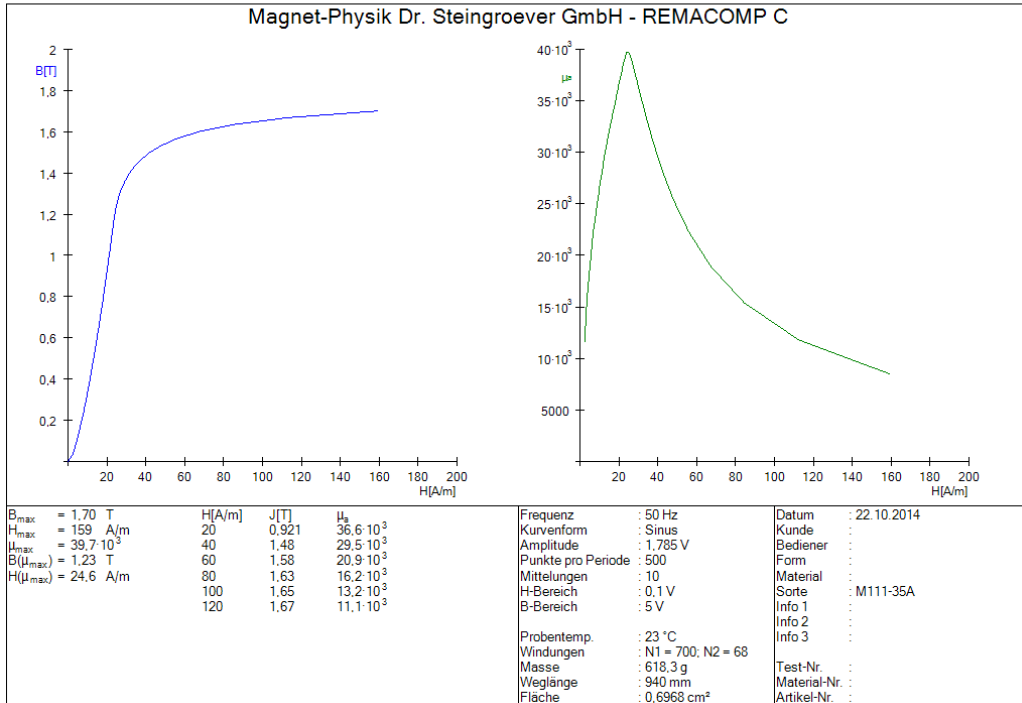

Commutation curve and permeability curve

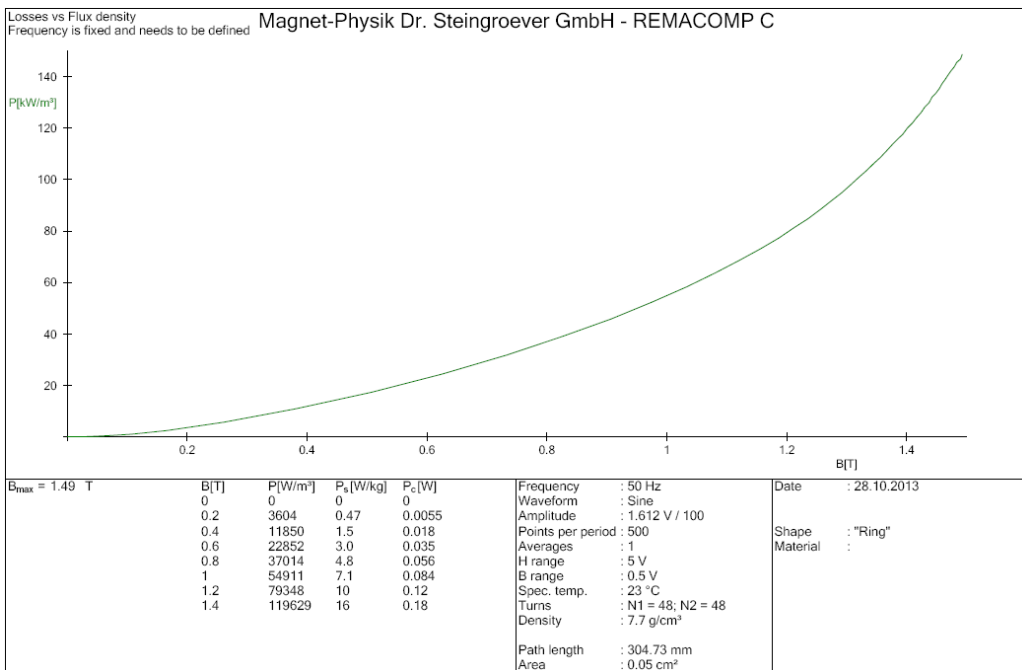

Losses P against flux density B



• **Technical Data**

REMACOMP® Model	C - 203 / C - 205	C - 1200	C - 2200
Frequency range	1 Hz to 10...20 kHz	1 Hz to 20 kHz	1 Hz to 20 kHz
Signal Generator (PC board)			
Resolution	16 bit	16 bit	16 bit
Max. output voltage	± 10 V	± 10 V	± 10 V
Waveforms, max. frequency / update rate	Arbitrarily programmable, up to 3.3·10 ⁶ points/s	Arbitrarily programmable, up to 3.3·10 ⁶ points/s	Arbitrarily programmable, up to 3.3·10 ⁶ points/s
Analog-to-Digital Converter (PC board)			
Simultaneous sampling	Yes	Yes	Yes
Number of inputs	2	2	2
Resolution	16 bit	16 bit	16 bit
Input voltage (full scale ranges)	±0.001 V to ±150 V,	±0.001 V to ±150 V,	±0.001 V to ±150 V,
Maximum input voltage	±150 V	±150 V	±150 V
Accuracy, better than	> 10 V: 0.4 % of reading > 0.2 V - 10 V: 0.2 % of reading > 0.02 V - 0.2 V: 0.9 % of reading ≤ 0.02 V: 3 % of reading	> 10 V: 0.4 % of reading > 0.2 V - 10 V: 0.2 % of reading > 0.02 V - 0.2 V: 0.9 % of reading ≤ 0.02 V: 3 % of reading	> 10 V: 0.4 % of reading > 0.2 V - 10 V: 0.2 % of reading > 0.02 V - 0.2 V: 0.9 % of reading ≤ 0.02 V: 3 % of reading
Maximum sampling rate	3.57·10 ⁶ points/s	3.57·10 ⁶ points/s	3.57·10 ⁶ points/s
- real time			
- random interleaved sampling	-	-	-
Power Amplifier 4-quadrant operation, various models available			
Max. current, standard model	C - 203: ±5 A C - 205: ±12 A	approx. ±30 A	approx. ±60 A approx. ±30 A (HV-Variant)
Max. current, alternate models	±2 A to ±20 A		
Max. voltage, standard model	C - 203: ±20 V C - 205: ±36 V	approx. ±150 V	approx. ±150 V approx. ±300 V (HV-Variant)
Max. voltage, alternate models	±20 V to ±100 V		
Approx. power	C - 203: 50 VA / 100 W C - 205: 200 VA / 400 W	approx. 1100 VA	approx. 2200 VA
Bandwidth	DC to 10 kHz...20 kHz (depending on model and operating mode)	DC to 300 kHz	DC to 300 kHz
Operating modes			
Voltage amplifier	Yes	Yes	Yes
Current amplifier	Yes	No	No
Low Inductance Shunt			
Resistance (depending on power amplifier model)	0.1 Ω to 1 Ω	0.2 Ω	0.05 Ω
Tolerance	0.1 %	0.1 %	0.1 %
Maximum burden	10 W	100 W	200 W
Special Features			
Automatic offset adjustment	Yes	Yes	Yes
DC bias	Yes	Yes	Yes
Waveform control for U ₂ (t) or B(t)	Yes	Yes	Yes

• Optional Accessories

• Coil Systems MC-REMACOMP®

Coil systems MC-REMACOMP® are used for the measurement of the polarization J of strips, sheet or bars of soft magnetic material. They consist of an open field coil and a measuring coil (surrounding coil). The sheared hysteresis loop is measured. The coil design is made according to the customer's requirements. Therefore information about specimen material, shape and dimensions is necessary.

• Measuring Yokes MJ-REMACOMP®

Closure yokes MJ-REMACOMP® are used in combination with coil systems MC-REMACOMP® in order to close the magnetic path. They are suitable to measure magnetic strips. The yokes are laminated and made from low core loss material. The yoke design is made to fit a coil system MC-REMACOMP®.

• Measuring Yokes MJC-REMACOMP® (Single Sheet or Strip Yokes)

Measuring yokes MJC-REMACOMP® contain integrated field generating and measuring coils. They are designed to measure magnetic strip and sheet. The yokes are laminated and made from low core loss material.

• High Frequency Epstein Frame MCE 1200 - 10 kHz (for REMACOMP® C - 1200)

This Epstein frame allows measurements in a frequency range from 200 Hz to 10 kHz. The number of turns of the primary winding can be switched between two values. The air flux compensation is carried out by calculation. The MCE 1200 - 10 kHz meets the requirements of the standards IEC 60404-10, DIN EN 10252 and ASTM A348/A348M.

• Multi-turn Winding Adapter CB-M (for REMACOMP® C - 203 / C - 205)

This connection box uses a connector with 40 pins to close prefabricated windings around a ring specimen. The windings are split into groups of 25, 10 and 5. Each of them or a combination can be used either as primary or as secondary winding. Minimum inner specimen diameter: 25.5 mm.



• Reference Specimen for Single Sheet Tester MJC 500 – Grain-Oriented Steel

This sheet with the dimensions 500 mm × 500 mm is made of grain-oriented electrical steel. It is supplied with a proprietary calibration certificate. It can optionally be supplied including a calibration carried out by PTB (Physikalisch-Technische Bundesanstalt).

• Reference Specimen for Single Sheet Tester MJC 500 – Non-Oriented Steel

This sheet with the dimensions 500 mm × 500 mm is made of non-oriented electrical steel. It is supplied with a proprietary calibration certificate for both orientations (measurement parallel towards the rolling direction and perpendicular to the rolling direction). It can optionally be supplied including a calibration carried out by PTB (Physikalisch-Technische Bundesanstalt).

• Reference Specimen for MJC 210 – NGO Steel –in rolling direction

This sheet with the dimensions 500 mm × 210 mm is made of non-oriented electrical steel. The 500 mm long side of this specimen is oriented parallel towards the rolling direction and allows measurements with the single sheet tester MJC 500, as well as with the single sheet tester MJC 210. It is supplied with a proprietary calibration certificate.

- **Reference Specimen for MJC 210 – NGO Steel – perpendicular rolling direction**

This sheet with the dimensions 500 mm x 210 mm is made of non-oriented electrical steel. The 210 mm long side of this specimen is oriented parallel towards the rolling direction and allows measurements with the single sheet tester MJC 500, as well as with the single sheet tester MJC 210. It is supplied with a proprietary calibration certificate.

- **Reference Specimen for Epstein Frame – Grain Oriented Steel**

This set of Epstein strips is made of grain oriented electrical steel. It is supplied with a proprietary calibration certificate. This reference specimen can optionally be supplied including a calibration carried out by PTB (Physikalisch-Technische Bundesanstalt).

- **Reference Specimen for Epstein Frame – Non-Oriented Steel**

This set of Epstein strips is made of non-oriented electrical steel. It is supplied with a proprietary calibration certificate. This reference specimen can optionally be supplied including a calibration carried out by PTB (Physikalisch-Technische Bundesanstalt).

- **Measuring Position Selector (for REMACOMP® C – 203 and C - 205)**

The measurement position selector allows automatically switching the secondary winding of multiple ring specimens to the AC input of the data acquisition system. Two versions are available: In the 20 inputs version one common pole is shared with all specimens. In the 10 inputs version both poles are switched. The primary windings of all specimens must be wired in series as the primary current is not switched.

- **Room temperature sensor TS-USB**

Temperature sensor for USB connection. Using this sensor the room temperature can be shown on the computer display and automatically be saved with the measurement.



- **Thermocouple and USB Thermocouple Interface**

This set comprises a non-magnetic (type-T) thermocouple for measuring the specimen temperature and a thermocouple interface that allows connecting the thermocouple to the computer. The temperature is automatically captured by the Comp software and saved with the measurement.

- **Oven (Temperature Chamber)**

This accessory allows measurements on ring specimens at other temperatures than room temperature. The standard model operates from 40 °C to 300 °C. Other temperature ranges are available. The chamber has a feed-through for the specimen connecting wires and thermocouple. A thermocouple for measuring the specimen temperature and a USB thermocouple module are included. The device is remotely controlled from the COMP software. Using the series measurement feature, this allows automatically running a sequence of measurements at different temperatures including a programmable temperature stabilization time prior to the individual measurements.

- **Services**

Taking into Operation and Training – at the Premises of MAGNET-PHYSIK

Training in the operation and software of the REMACOMP®.

The training takes 1 - 2 days (depending on model) and is included in the standard packages. The customer bears all costs in connection with the journey, stay, accommodation, etc.

Taking into Operation and Training – at the premises of the Customer

Training in the operation and software of the REMACOMP®.

The training takes 1 - 2 days (depending on model) and is at the customer's expense. Additionally the customer bears the costs for our employee in connection with the journey (incl. expenses for travel time, stay, accommodation, etc.).

Further information, also about the REMACOMP® C, can be found in our brochure

MAGNETIC MEASURING TECHNIQUES

by Dr. E. Steingroever
and
Dr. G. Ross

Due to continuous product improvements, specifications are subject to change without notice.



MAGNET-PHYSIK Dr. Steingroever GmbH

Emil-Hoffmann-Straße 3, 50996 Cologne, Germany
Phone: +49 2236 3919-0 • Fax: +49 2236 3919-19
info@magnet-physik.de
www.magnet-physik.de

MAGNET-PHYSICS Inc.

6330 East 75th Street, Suite 224, Indianapolis, IN 46250, USA
Phone: +1 317 577 8700 • Fax: +1 317 578 2510
info@magnet-physics.com
www.magnet-physics.com